

PURKEYS

Trailer Auxiliary Power System (Taps)[™]

INSTALLATION GUIDE





CONTENTS

General Information	2
System Diagram for Dual Pole Application	3
System Diagram for Straight Truck Application	4
Dual Pole Configuration.....	5
Straight Truck Configuration.....	5
Mounting the TAPS Enclosure	6
120 VAC Harness Installation.....	7
Input Cable Routing for Dual Pole Application	11
Input Cable Routing for Straight Truck Application	13
LED Indication and Operation.....	15
Limited Commercial Warranty Policy.....	16

GENERAL INFORMATION

The Trailer Auxiliary Power System (TAPS)[™] is designed to provide auxiliary AC power at 120 volts in a trailer so that AC devices can be powered while on the trailer. In this application, the AC power allows a device such as an electric pallet jack to be charged while the truck is driving between stops. It keeps the pallet jack at a high state of charge so it stays functional during the hours of operation.

This trailer-based system receives DC power from the tractor via the dual pole power cord. If mounted on a straight truck, it receives DC power from the tractor batteries. TAPS converts DC power to 120 volt AC power and is managed by a smart inverter that will not turn on until it sees a DC input of 12.8 volts.

Once the inverter turns on, it will stay on until the voltage drops below 12.4 volts for 30 seconds, or until the voltage drops below 10.5 volts. Once the inverter turns off, it will not turn back on until the voltage again reaches at least 12.8 volts.

TAPS INSTALLATION GUIDE

SYSTEM DIAGRAM FOR DUAL POLE APPLICATION

Components:

- Dual pole nosebox
- Dual pole positive (+)
- Dual pole negative (-)
- Inverter
- Liquid tight conduit with 110 VAC harness
- 110 VAC receptacle with LED indication
- Reinforced nylon receptacle box
- 1500 Watt pure sine inverter
- 20' Dual pole negative cable
- Dual pole positive cable

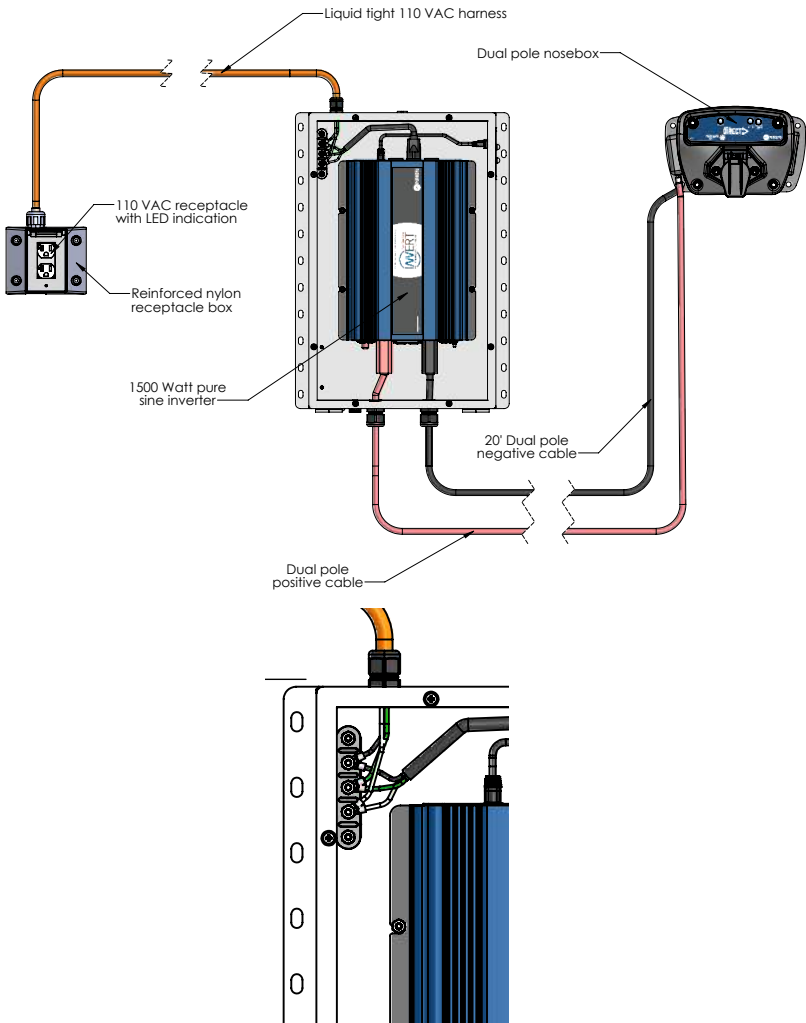

AC connections at the 4-terminal junction strip

SYSTEM DIAGRAM FOR STRAIGHT TRUCK APPLICATION

Components:

- 150 amp fuse cube and bracket
- Dual pole positive (+)
- Dual pole negative (-)
- Inverter
- Liquid tight conduit with 110 VAC harness
- 110 V receptacle with power indication

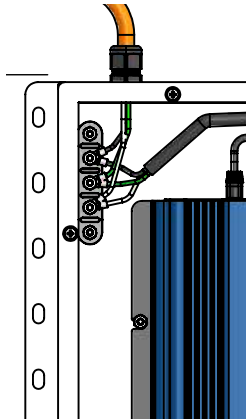
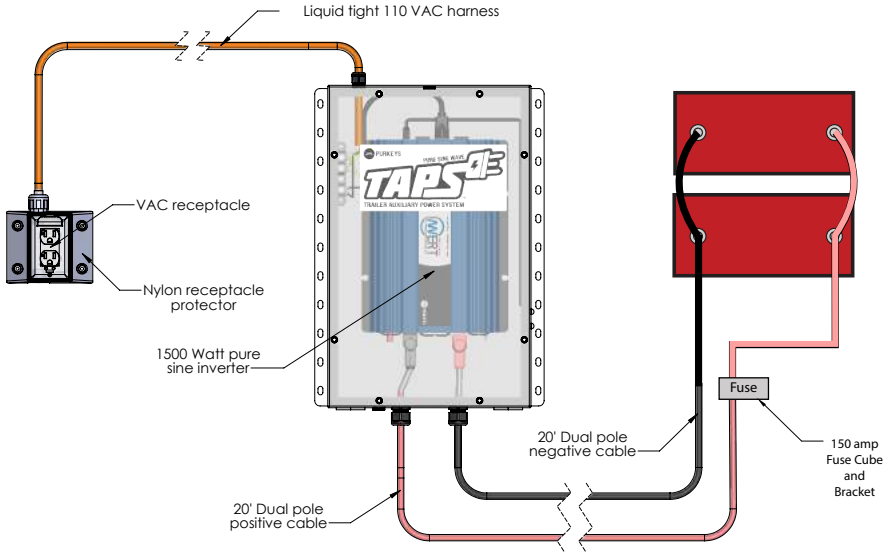

AC connections at the 4-terminal junction strip

TAPS INSTALLATION GUIDE

DUAL POLE CONFIGURATION

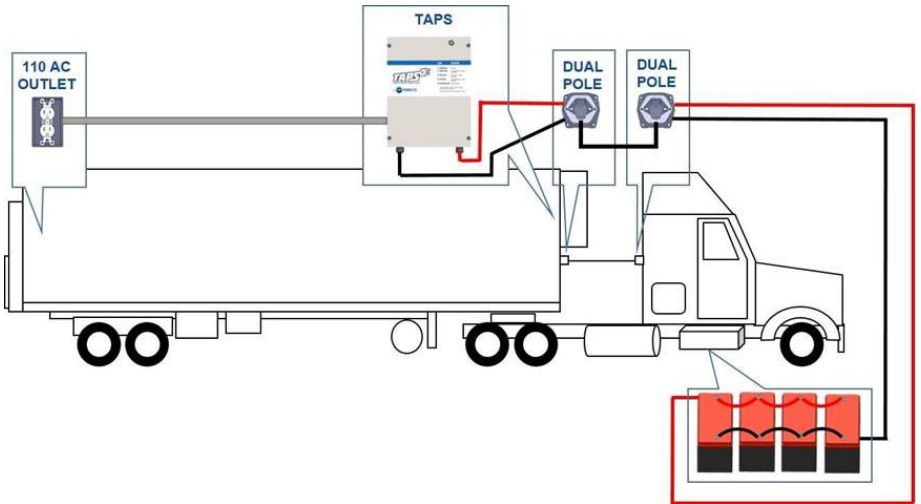

STRAIGHT TRUCK CONFIGURATION

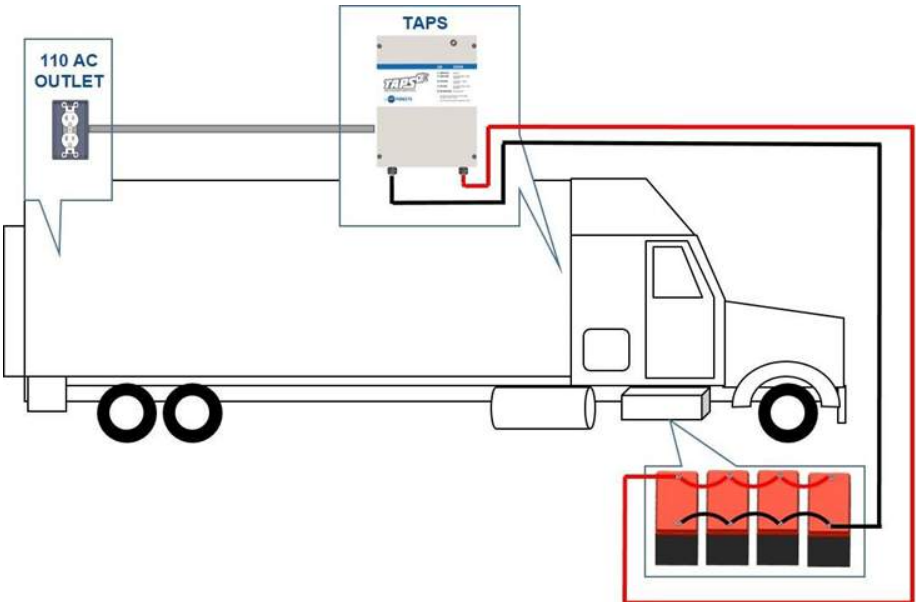

MOUNTING THE TAPS ENCLOSURE

Step 1: Mount the TAPS enclosure in a suitable location, either inside or outside of the trailer, using the universal mounting brackets.

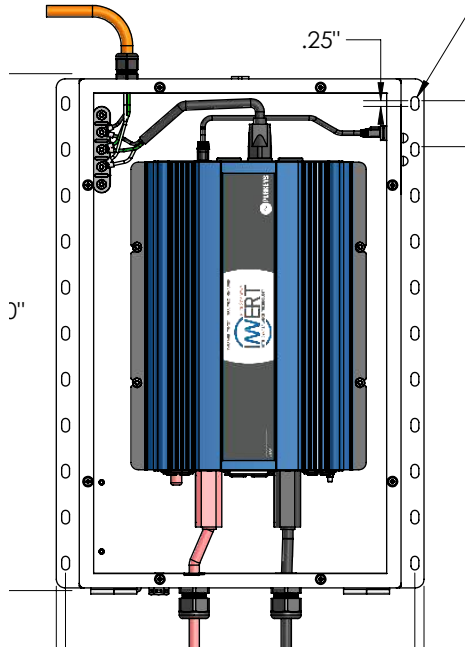

TAPS enclosure mounting complete.

TAPS INSTALLATION GUIDE

120 VAC HARNESS INSTALLATION

Step 1: Route the end of the 120 VAC harness that contains the three wires with the #10 eyelets through the hole at the top of the TAPS enclosure. Secure the harness to the enclosure using the supplied liquid-tight fitting.



Important! To reduce the risk of electrical shock, make sure the inverter does not have power before making the following connections.

Step 2: Attach the white wire to the top post, the green wire to the 2nd post, and the black wire to the 3rd post. Tighten each connection.

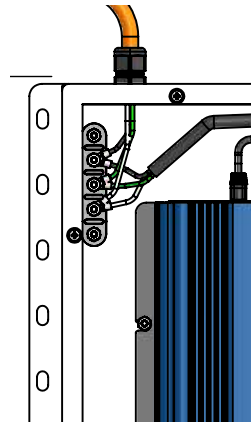

Step 3: Once the connections are complete, close the lid, then install all 8 lid screws (included). Torque to 5 lb-in. DO NOT exceed 7 lb-in or screws can be damaged.



Step 4: Route the AC harness. (If the TAPS is inside the trailer, route the harness to the corner where the side wall and the ceiling meet. Route along this edge all the way to the back of the trailer. Use the supplied cable clamps to secure the harness to the trailer wall.)



Note: To prevent the AC harness from sagging, place the cable clamps approximately every 18 inches.

Step 5: Mount the sealed AC receptacle box in a suitable location on the side wall at the back of the trailer.



Note: It may be necessary to recess the receptacle into the trailer wall to prevent it from getting damaged. Consult with your trailer manufacturer first.

Step 6: Route the three AC wires into the AC receptacle box and secure the harness to the box using the supplied liquid-tight connector.



TAPS INSTALLATION GUIDE

Step 7: Ensure the AC wires will reach the location on the AC receptacle where they will be secured and cut off the excess wire.

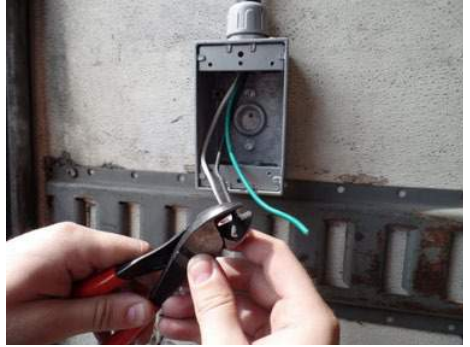

Step 8: Strip ¼ inch of insulation off the ends of all three AC wires and crimp on the supplied #10 spade terminals. Apply heat to shrink the heat shrink on the spade terminals.



Step 9: Connect the white wire to the silver screw, the green wire to the green screw, and the black wire to the gold screw on the AC receptacle.



Step 10: Place the supplied foam gasket and plastic face plate over the AC receptacle. Insert the AC receptacle into the AC receptacle box and tighten the mounting screws.



Step 11: Install the AC receptacle cover.



110 VAC harness installation complete.

TAPS INSTALLATION GUIDE

INPUT CABLE ROUTING FOR DUAL POLE APPLICATION (ROUTING INSIDE TRAILER)

Step 1: Route the 1/0 red and black input cables down the trailer wall. Secure the cables separately to the trailer wall using the supplied plastic clamps.



Important: Ensure that the positive and negative cables are routed so they cannot touch. Due to normal vibrations, the cables could potentially rub through the insulation and cause a short if they are touching.

Step 2: Route the 1/0 red and black input cables through the trailer wall and out to the dual pole nosebox and mount the nosebox on the front of the trailer.



Note: Cut the cables to length once a the dual pole nosebox has been determined.

Step 3: Once the cables are through the trailer wall, crimp the supplied 3/8 inch cable lug onto the 1/0 red positive cable. Apply heat to the heat shrink to seal the connection.

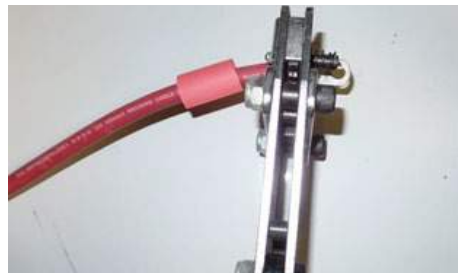

Step 4: Crimp the supplied $\frac{1}{4}$ inch cable lug onto the 1/0 black negative cable. Apply heat to the heat shrink to seal the connection.



Step 5: Remove the cover on the side of the nosebox.

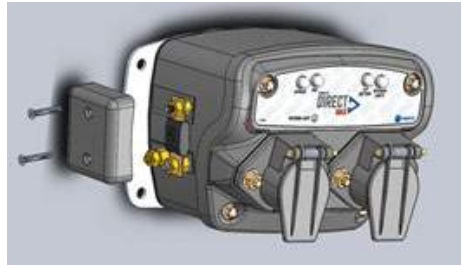

Step 6: Install the 1/0 cables, attaching the black cable to the negative cable stud and the red cable to the positive cable stud. Replace the side cover.

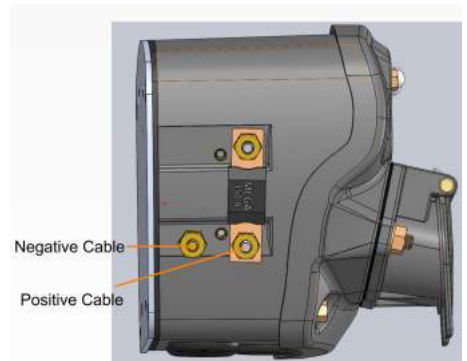

Input cable routing for dual pole application complete.

TAPS INSTALLATION GUIDE

INPUT CABLE ROUTING FOR STRAIGHT TRUCK APPLICATION (ROUTING INSIDE TRAILER)

Step 1: Route the 1/0 red and black input cables down the trailer wall. Secure the cables separately to the trailer wall using the supplied plastic clamps.



Important! Ensure that the positive and negative cables are routed so they cannot touch. Due to normal vibrations, the cables could potentially rub through the insulation and cause a short if they are touching.

Step 2: Route the 1/0 red and black input cables through the trailer wall or floor toward the vehicle battery box. It may be necessary to use the supplied cable pass-through plate as shown in this picture. Using a 3 1/2 inch hole saw, cut a hole in the wall or floor to mount the cable pass-through plate.



Step 3: Once the cables are through the trailer wall or floor, ensure they will reach the positive and negative posts on the vehicle batteries. Plan for a little slack in the cables and cut off any excess cable.



Step 4: Crimp the supplied 3/8 inch cable lugs onto the 1/0 black negative cable and the 1/0 red positive cable. Apply heat shrink to seal the connection.



Step 5: Attach the supplied fuse cube and bracket assembly to the 1/0 red positive cable. Tighten the fuse cube nut.



Note: The fuse cube nut is tapered to ensure that the nut is tightened all the way so there is no air gap between the cable lug and the fuse cube nut.

Step 6: Attach the fused 1/0 red positive cable to the vehicle positive battery post and the 1/0 black negative cable to the vehicle negative battery post.



Important: Make sure that the AC harness installation is complete before making connections at the vehicle batteries.

Input cable routing for straight truck application complete.

TAPS INSTALLATION GUIDE

LED INDICATION AND OPERATION



	LED	STATUS
AC Power LED	Green Solid	TAPS unit is functioning.
	Orange Solid	TAPS unit is off.
Fault LED	Orange Solid	Undervoltage.
	Orange Blink	Overvoltage.
	Yellow Solid	Over power.
	Yellow Blink	Over temperature.
	System Fault	Contact Purkeys at 1-800-219-1269 for assistance.

LIMITED COMMERCIAL WARRANTY POLICY

Purkeys Fleet Electric, Inc. (hereafter “Purkeys”), warrants each product to be free of defects in material or workmanship under normal use and service. This warranty is for the benefit of Original Equipment Manufacturers, Dealers, Warehouse Distributors, Fleets, or other End Users (hereafter “Customers”) and covers products manufactured by Purkeys and sold new to Customers either directly by Purkeys or by its authorized dealers, distributors, or agents. The length of the Warranty Period is 36 months.

The warranty period commences on the in-service or install date and is not transferable. Failure to provide the in-service or install date on the warranty claim form will cause the warranty period to begin on the date the part was manufactured or date of sale recorded on the original sales invoice, whichever is earlier.

A completed warranty claim form should accompany all parts submitted to Purkeys for consideration for repair or replacement under warranty. The submitted claim form should contain all of the information required. Lack of a properly or fully completed claim form will result in delay or denial of warranty claim. Claims must be submitted no later than 30 days after part is removed.

This warranty does not apply if, in sole judgement of Purkeys, the product has been damaged or subjected to accident, faulty repair, improper adjustment, improper installation or wiring, neglect, misuse, or alteration or if the product failure is caused by defects in peripheral vehicle components or components attached to the Product or failure of a part not manufactured by Purkeys.

This warranty shall not apply if any Purkeys product is used for a purpose for which it is not designed or is in any way altered without the specific prior written consent of Purkeys. ANY Product alleged by a Customer to be defective must be inspected by Purkeys as a part of the warranty claims process in order to confirm that the part has failed as a result of a defect in material or workmanship.

Transportation for products and parts submitted to Purkeys for warranty consideration must be prepaid by Customer. Repaired or replaced products and or components will be returned to Customer pre-paid by Customer or “freight collect” to the address provided by Customer in the warranty claim form. No charge will be made for labor or material in effecting such repairs.

The Warranty provided by Purkeys hereunder is specifically limited to repair or replacement of the Product as Purkeys deems most appropriate in its sole discretion. Purkeys neither assumes nor authorizes any other person to assume on its behalf any other warranty or liabilities in connection with Purkeys products. The Warranty does not apply to fuses or other “consumable” or maintenance items which are or may be a part of any Purkeys product.

THIS WARRANTY DOES NOT APPLY TO LOSS OF VEHICLE OR EQUIPMENT, LOSS OF TIME, INCONVENIENCE, OR OTHER INCIDENTAL OR CONSEQUENTIAL DAMAGES. PURKEYS SPECIFICALLY DISCLAIMS AND SHALL NOT BE LIABLE FOR INCIDENTAL OR CONSEQUENTIAL DAMAGES arising out of or from the use of Purkeys products by the Customer.

THIS LIMITED WARRANTY IS IN LIEU OF ALL OTHER WARRANTIES, INCLUDING COMMON LAW WARRANTIES OF FITNESS FOR A PARTICULAR PURPOSE, MERCHANTABILITY, AND ANY OTHER EXPRESS OR IMPLIED WARRANTIES. ALL OTHER SUCH WARRANTIES ARE SPECIFICALLY DISCLAIMED.

This Limited Commercial Warranty supersedes all previous Warranty Policies issued by Purkeys and any of its suppliers.

TAPS INSTALLATION GUIDE



WATT Keeps You Trucking