

PURKEYS

SEVERE SERVICE TRAILER LINK

INSTALLATION GUIDE





CONTENTS

General Information	2
Select System Diagram	3
Direct System Diagram.....	3
Installation.....	4
Part List.....	7
Limited Commercial Warranty Policy.....	9

GENERAL INFORMATION

A Purkeys Select™ or Direct™ charging system can be enhanced by being paired with a parallel circuit powered by a dual pole connection. This Severe Service Trailer Link kit for Select or Direct provides an added route for power to travel to the trailer liftgate batteries. This kit works seamlessly in conjunction with the Select or Direct system.

The Select and Direct use two-stage battery charging: bulk charging and topping off. When a trailer is equipped with a Severe Service Trailer Link with a Select or Direct, the Severe Service Trailer Link helps during the early stages of bulk charging (when the battery is low or right after the liftgate is operated). As the battery state of charge increases, the Select or Direct takes over the charging until the batteries are fully charged. This occurs because the voltage level supplied by the dual pole alone is not as capable of topping off the charge of the liftgate batteries. The Select or Direct in parallel with the dual pole assures that both the bulk charging and topping off of the liftgate batteries are optimized.

SEVERE SERVICE TRAILER LINK

SELECT SYSTEM DIAGRAM

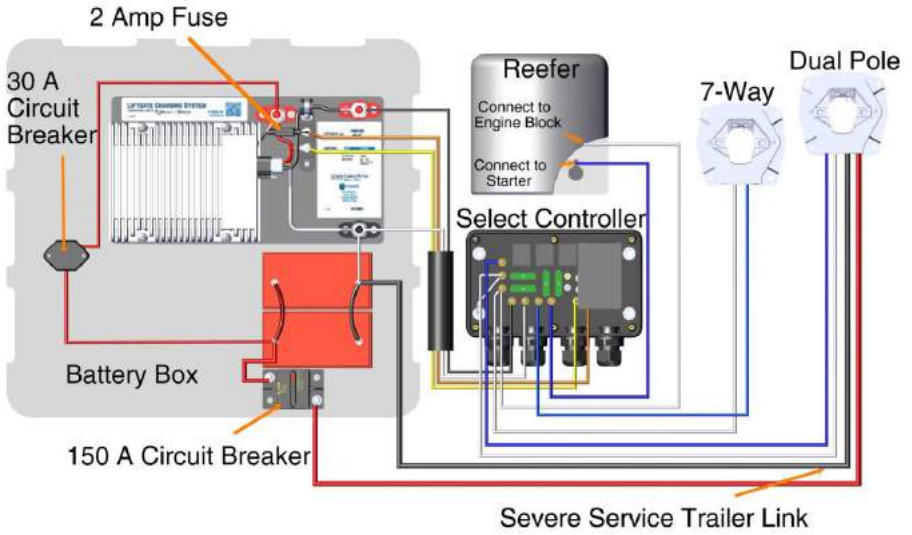

DIRECT SYSTEM DIAGRAM

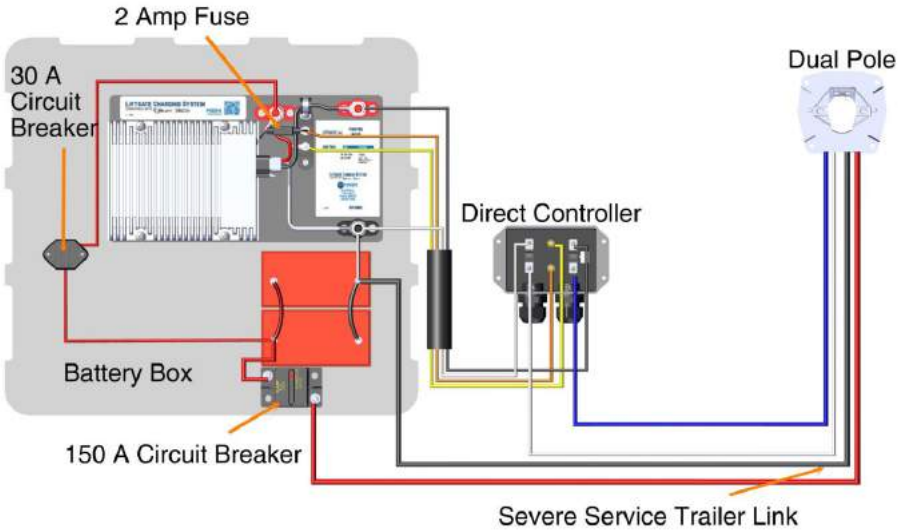

INSTALLATION

Step 1: Determine a suitable location to mount the circuit breaker inside the liftgate battery box. Using the circuit breaker as the template, drill mounting holes with $\frac{1}{4}$ " drill bit.



Step 2: Install circuit breaker using provided hardware.



Step 3: Connect the red charge cable from the circuit breaker marked "Liftgate Battery (+)," to the liftgate battery positive post. Install nut and tighten.



Step 4: Remove the dual pole receptacle from the front of the trailer so that the connections on the inside of the box can be accessed. Remove the bolts connecting the positive and negative wires to the dual pole receptacle.



SEVERE SERVICE TRAILER LINK

Step 5: Route the red charge cable and black cable into the dual pole nosebox. Connect the black cable and 10-gauge white wire to the negative side of the dual pole receptacle. Connect the red charge cable and the 10-gauge blue wire to the positive side of the dual pole receptacle. Tighten bolts and reinstall dual pole nosebox to the trailer.



Step 6: Route the red charge cable and black cable on the front of the trailer and under the header plate using the access points and pathways provided by the trailer manufacturer. Securely attach cabling with the holddowns and fasteners provided.

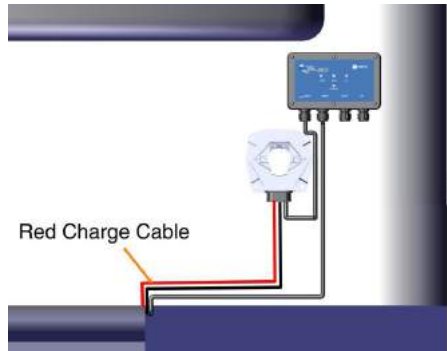

IMPORTANT: Avoid sharp edges and possible chaffing points.

Step 7: Route the red and black cables toward the back of the trailer via the pathways provided by the trailer manufacturer. Secure with wire ties as you go.



IMPORTANT: Avoid sharp edges and possible chaffing points.

Step 8: Route the red and black cables into the liftgate battery box and secure the cables with the provided wire ties.



Step 9: Route and connect the red cable marked “Circuit Breaker” to the input side of the circuit breaker.

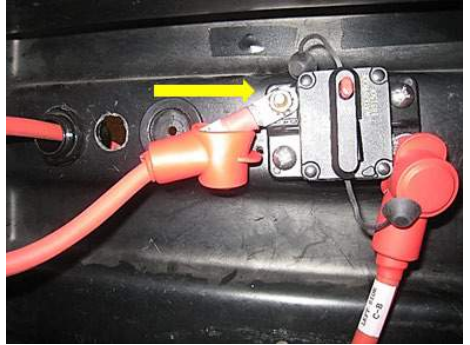

Step 10: Slide red boot over connection to protect from a short.

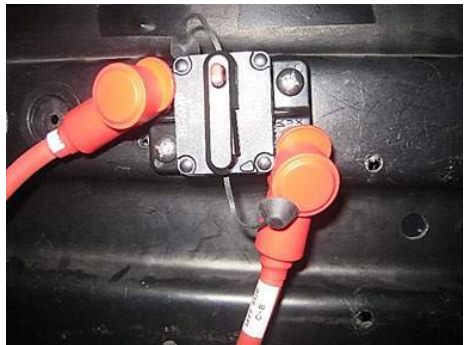

Step 11: Route and connect the black cable marked “Liftgate Battery (-)” to the liftgate battery negative post.



SEVERE SERVICE TRAILER LINK

PART LIST

Cable Assembly, Black to LG Battery Ground

Part Numbers:

CA00148: 53FT

CA00150: 48FT

CA00152: 23FT



Cable Assembly, Red to Circuit Breaker

Part Numbers:

CA00147: 53FT

CA00149: 48FT

CA00151: 23FT



Bag Kit

Part Number:

BK-1063



Cable Assembly, 2 AWG Red from Circuit Breaker to LG Battery Positive

Part Number:

CA00146



Installation Guide

Part Number:

INST050



Part #	Description	Parts Contained
CA00143	SEVERE SERVICE TRAILER LINK 53 FT, 2 AWG	CA00148, CA00147, BK-1063, AND CA00146*
CA00144	SEVERE SERVICE TRAILER LINK 48 FT, 2 AWG	CA00150, CA00149, BK-1063, AND CA00146*
CA00145	SEVERE SERVICE TRAILER LINK 23 FT, 2 AWG	CA00152, CA00151, BK-1063, AND CA00146*

*Pictures of these parts can be seen on page 7.

SEVERE SERVICE TRAILER LINK

LIMITED COMMERCIAL WARRANTY POLICY

Purkeys Fleet Electric, Inc. (hereafter “Purkeys”), warrants each product to be free of defects in material or workmanship under normal use and service. This warranty is for the benefit of Original Equipment Manufacturers, Dealers, Warehouse Distributors, Fleets, or other End Users (hereafter “Customers”) and covers products manufactured by Purkeys and sold new to Customers either directly by Purkeys or by its authorized dealers, distributors, or agents. The length of the Warranty Period is 36 months.

The warranty period commences on the in-service or install date and is not transferable. Failure to provide the in-service or install date on the warranty claim form will cause the warranty period to begin on the date the part was manufactured or date of sale recorded on the original sales invoice, whichever is earlier.

A completed warranty claim form should accompany all parts submitted to Purkeys for consideration for repair or replacement under warranty. The submitted claim form should contain all of the information required. Lack of a properly or fully completed claim form will result in delay or denial of warranty claim. Claims must be submitted no later than 30 days after part is removed.

This warranty does not apply if, in sole judgement of Purkeys, the product has been damaged or subjected to accident, faulty repair, improper adjustment, improper installation or wiring, neglect, misuse, or alteration or if the product failure is caused by defects in peripheral vehicle components or components attached to the Product or failure of a part not manufactured by Purkeys.

This warranty shall not apply if any Purkeys product is used for a purpose for which it is not designed or is in any way altered without the specific prior written consent of Purkeys. ANY Product alleged by a Customer to be defective must be inspected by Purkeys as a part of the warranty claims process in order to confirm that the part has failed as a result of a defect in material or workmanship.

Transportation for products and parts submitted to Purkeys for warranty consideration must be prepaid by Customer. Repaired or replaced products and or components will be returned to Customer pre-paid by Customer or “freight collect” to the address provided by Customer in the warranty claim form. No charge will be made for labor or material in effecting such repairs.

The Warranty provided by Purkeys hereunder is specifically limited to repair or replacement of the Product as Purkeys deems most appropriate in its sole discretion. Purkeys neither assumes nor authorizes any other person to assume on its behalf any other warranty or liabilities in connection with Purkeys products. The Warranty does not apply to fuses or other “consumable” or maintenance items which are or may be a part of any Purkeys product.

THIS WARRANTY DOES NOT APPLY TO LOSS OF VEHICLE OR EQUIPMENT, LOSS OF TIME, INCONVENIENCE, OR OTHER INCIDENTAL OR CONSEQUENTIAL DAMAGES. PURKEYS SPECIFICALLY DISCLAIMS AND SHALL NOT BE LIABLE FOR INCIDENTAL OR CONSEQUENTIAL DAMAGES arising out of or from the use of Purkeys products by the Customer.

THIS LIMITED WARRANTY IS IN LIEU OF ALL OTHER WARRANTIES, INCLUDING COMMON LAW WARRANTIES OF FITNESS FOR A PARTICULAR PURPOSE, MERCHANTABILITY, AND ANY OTHER EXPRESS OR IMPLIED WARRANTIES. ALL OTHER SUCH WARRANTIES ARE SPECIFICALLY DISCLAIMED.

This Limited Commercial Warranty supersedes all previous Warranty Policies issued by Purkeys and any of its suppliers.



WATT Keeps You Trucking