

PURKEYS

SELECT™

DIAGNOSTIC GUIDE





CONTENTS

General Information.....	2
Select Call-Outs.....	3
Wire Diagram and Legend	4
Diagnostics.....	6
Excessive Voltage Drop Diagnostics	6
Static Diagnostics.....	7
Stinger Diagnostics	9
Reefer Diagnostics	12
AUX Diagnostics.....	15
Charging Diagnostics	19
Testing the DC/DC converter	21
Summary.....	25
Limited Commercial Warranty Policy	29

GENERAL INFORMATION

The Purkeys' Select™ system allows charging from multiple sources and improves the charging of liftgate batteries by utilizing a DC/DC converter to boost the voltage for optimal charging. The boost in voltage overcomes the normal voltage drop caused by the extended distance between the liftgate batteries and the vehicle charging system. Also, in cold temperatures batteries require increased charging voltages to maintain a high state of charge. The DC/DC converter in the Select system compensates for temperature by providing higher charging voltages in cold weather. The result is well-charged liftgate batteries that will last longer and have ample power for liftgate operation.

The Select system is automatic and has easy-to-interpret LED indicators to assure drivers and technicians of proper system function. The Select Controller increases the time that the DC/DC converter can charge the liftgate batteries by automatically choosing the best available source of power (tractor or reefer) and by monitoring the source power and “extending” the liftgate battery charge time to take full advantage of the available power, without compromising the source batteries' ability to crank the engine.

The Select system provides opportunity charging for liftgate batteries that is essential in low mileage, high frequency liftgate operation applications. The LED indicators clearly show the status of the source as well as the status of the liftgate batteries. A quick glance at the Select Controller assures the driver that the liftgate batteries are ready to go, or alerts the driver that the batteries need maintenance.

SELECT DIAGNOSTIC GUIDE

SELECT CALL-OUTS

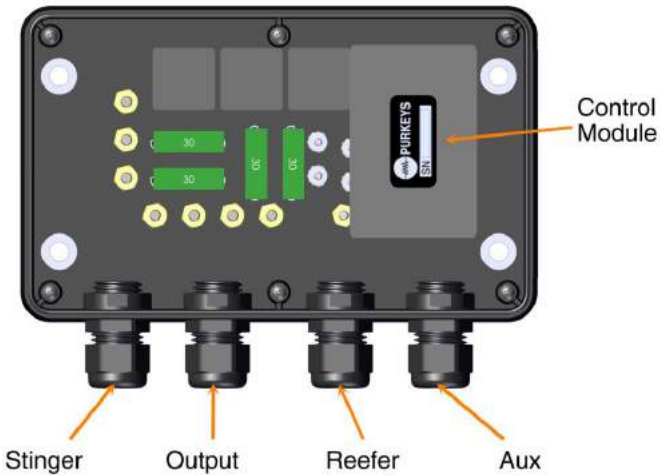
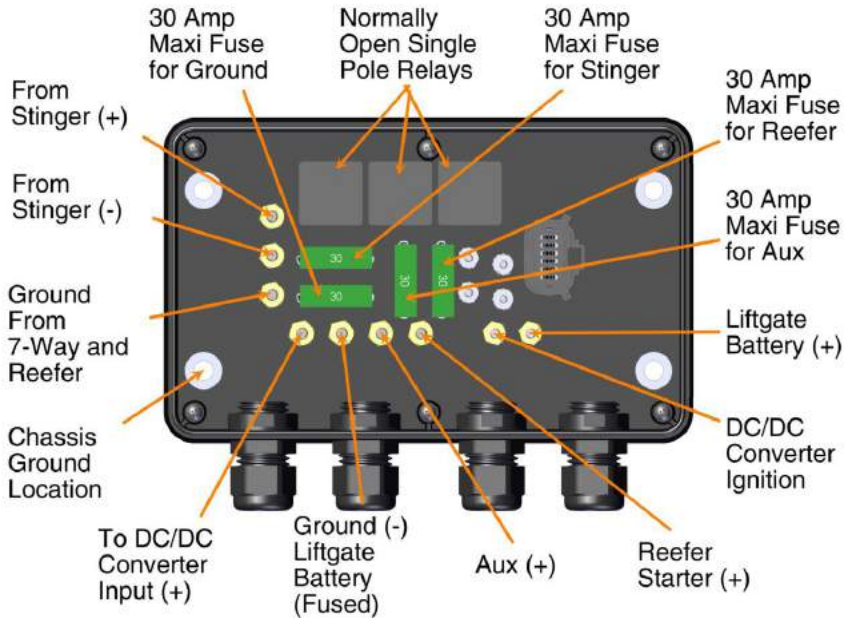

WIRE DIAGRAM AND LEGEND

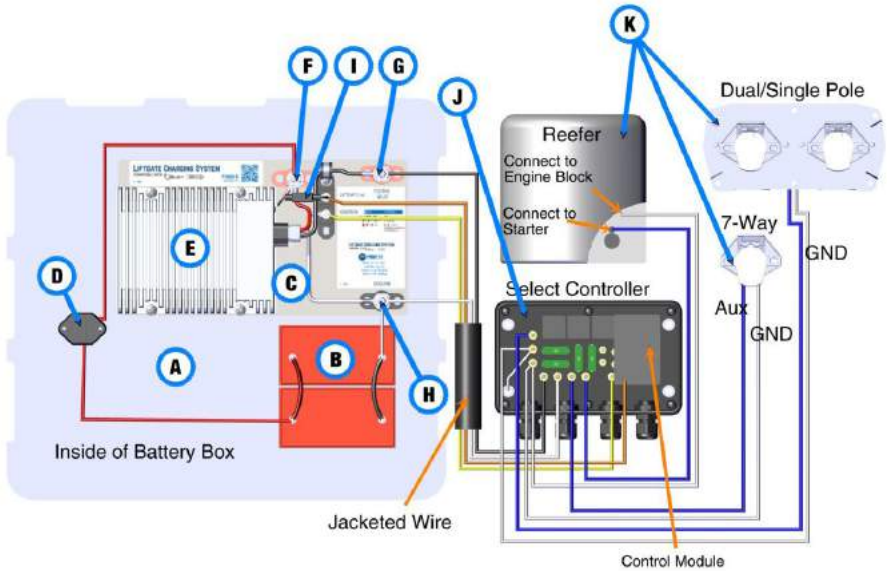

- A. Liftgate Battery Box
- B. Liftgate Battery Pack
- C. P1020-K Liftgate Charging System Plate Assembly
- D. 30 Amp Circuit Breaker
- E. DC/DC Converter
- F. DC/DC Converter Output Stud
- G. DC/DC Converter Input Stud (+)
- H. DC/DC Converter Input Stud (-)
- I. 2 Amp Inline Fuse from Liftgate Batteries
- J. Select Controller
- K. Input Source (Stinger, 7-Way, Straight Truck Battery Pack, or Reefer Unit)

SELECT DIAGNOSTIC GUIDE

WIRE COLOR	WIRE GAUGE	CONNECT FROM	CONNECT TO
Blue	10	Power In	Input Source (+) (stinger, 7-way, straight truck battery pack, or reefer unit)
White	10	Ground	Input Source (-)
White	8	Ground Liftgate Battery (-) Fused	DC/DC Converter Input Stud (-)
Yellow	16	DC/DC Converter Ignition	DC/DC Converter Ignition Stud
Black	8	Select Controller Power Out to DC/DC converter	DC/DC Converter Input (+)
Orange	14	Trailer Battery Sense (Controller Power)	Positive Liftgate Battery (+)

DIAGNOSTICS

EXCESSIVE VOLTAGE DROP DIAGNOSTICS

If there is excessive voltage drop between the source battery and the Select Controller, both Source and Lift Battery LEDs will briefly turn green, indicating that the Select is trying to charge the batteries. Then both LEDs will toggle orange for a few seconds. This cycle then repeats (this could happen on any input source; see Figure 1 for examples showing this issue on the 7-way aux input).

The circuit needs to be tested while under load to determine what is causing the excessive voltage drop. See the Stinger, Reefer, and Aux Diagnostics sections for details on diagnosing excessive voltage drop issues.



Figure 1: LEDs briefly turn green, toggle orange, then repeat



SERVICE TIP - Purkeys offers the Liftgate Double Check tool, which can simplify the diagnosis of liftgate charging system problems caused by excessive voltage drop. For more information on the tool, please call 1-800-219-1269 or visit our website at www.purkeys.net.

SELECT DIAGNOSTIC GUIDE

STATIC DIAGNOSTICS

Not connected to a charging source or not charging (at rest) (see Figure 2 for location of Liftgate Battery LED; see Figure 3 for LED status reference, located on right side of Select Controller).



Figure 2



Figure 3

LED STATUS	CONDITION	ACTION NEEDED	REFERENCE
Slow Flashing Green	Liftgate batteries in good state of charge (more than 12.4 volts).	None.	
Slow Flashing Orange	Liftgate batteries in low state of charge (voltage between 9.0 and 12.4 volts).	Charge and test batteries.	
Rapid Flashing Orange	Open ground fuse.	Repair circuit and/or replace fuse.	Ref #1
No LED	Open circuit between liftgate battery positive and Select Controller or disconnected ground in liftgate battery box.	Repair circuit, reset circuit breaker, or replace fuse.	Ref #2

REFERENCE #1

Rapid Flashing Orange LED:
Repair ground circuit and/or
replace ground fuse (see
Figure 4 for ground fuse
location).

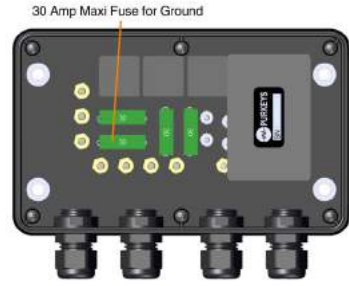

Figure 4

REFERENCE #2

No LED: Open circuit between liftgate battery positive or liftgate battery ground and the Select Controller. Follow the steps below to diagnose the No LED Status (see Figure 5).

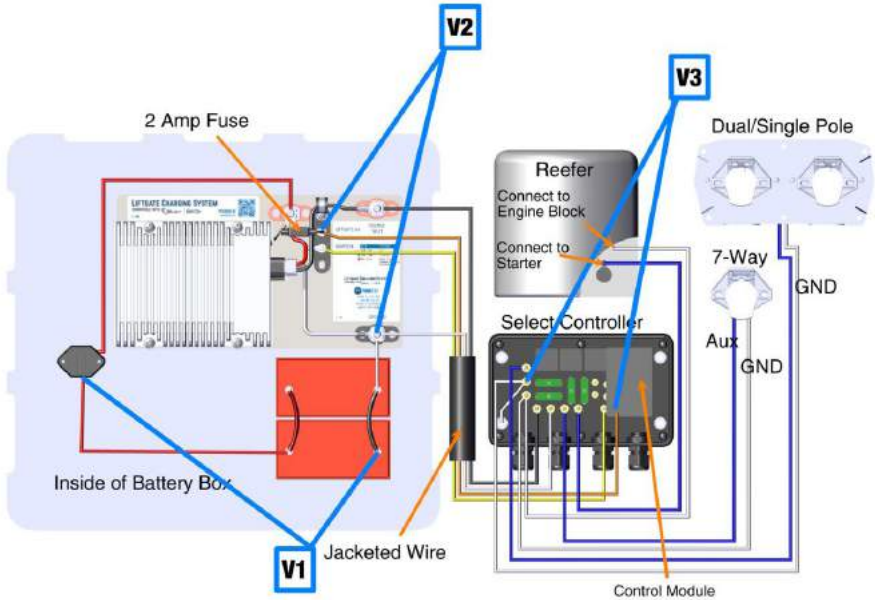

Figure 5

Step 1: Using a voltmeter, measure the voltage between the DC/DC converter side of the circuit breaker and the negative post on the liftgate battery (see V1 in Figure 5). If the reading is less than 12.0 V, charge or replace the batteries. If the battery reading is higher than 12.0 V, move to step 2.

SELECT DIAGNOSTIC GUIDE

Step 2: Using a voltmeter, measure the voltage between the positive and negative studs on the plate inside the battery box (see V2 in Figure 5). If there is no voltage reading, the issue is either the circuit breaker or the wire from one of these studs to the circuit breaker. Replace the circuit breaker or repair/replace the wire. If there is battery voltage, move to step 3.

Step 3: Using a voltmeter, measure the voltage between the ground stud from the 7-way/reefer and the liftgate battery positive stud inside the Select Controller (see V3 in Figure 5). Liftgate battery voltage should read 12.0 or higher. If not, check the 2-amp fuse and replace if necessary. If there is still no voltage reading, repair or replace the wires between the battery box and the Select Controller. Once these steps are completed, if there are still no LEDs, call customer service as the Select Controller may not be functioning properly.

STINGER DIAGNOSTICS

Unplug the 7-way, turn off the reefer, plug in the stinger, and start the tractor (see Figure 6 for location of Stinger LED; see Figure 7 for LED status reference, located on right side of Select Controller).



Figure 6



Figure 7

LED STATUS	CONDITION	ACTION NEEDED	REFERENCE
Solid Green	Charging with stinger as source.	Verify that liftgate battery is charging (see Charging Diagnostics section on page 19).	
Slow Flashing Orange	Input voltage from the stinger cord has dropped to less than 12.4 volts.	Determine cause for low voltage condition and repair.	Ref #4
Slow Flashing Green	Input voltage from stinger cord is between 12.4 and 13.8 volts.	Determine cause for low voltage condition and repair.	Ref #4
Rapid Flashing Orange	Blown fuse on the stinger circuit.	Repair the circuit and then replace the fuse.	Ref #3
No LED	No voltage from the stinger cord.	Determine where the problem exists and repair or replace the circuit.	Ref #4
Green, then Toggling Orange and Repeating	Excessive voltage drop.	Replace or repair the source power and ground wire harness.	Ref #5

REFERENCE #3

Rapid Flashing Orange LED: Blown Fuse on the stinger circuit. Replace the fuse (see Figure 8 for stinger fuse location).

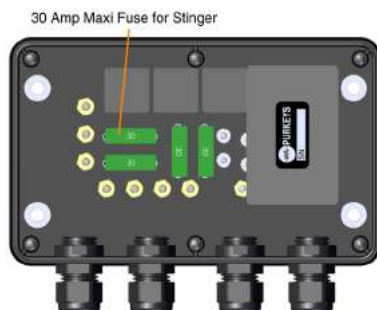

Figure 8

SELECT DIAGNOSTIC GUIDE

REFERENCE #4

Input voltage has not reached 13.8 volt turn-on threshold. Follow the steps below to diagnose.

Step 1: With the stinger cord still plugged in, and the tractor running, use a voltmeter to measure the voltage between the dual pole positive stud and the dual pole negative stud inside the Select Controller (see V1 in Figure 9). It should read 13.8 volts or greater. If yes, and the light still is not solid green, call customer service, as the Select Controller or Control Module may be defective. If no, proceed to step 2.

Step 2: With the stinger cord still plugged in, and the tractor running, use a voltmeter to measure the voltage between the positive and negative poles in the stinger receptacle (see V2 in Figure 9). It should read 13.8 volts or greater. If yes, repair or replace the wiring between the stinger and the Select Controller. If no, measure the voltage at the truck battery. If the reading is greater than 13.8 volts, the issue is the wire from the stinger to the truck. If the reading is less than 13.8 volts, the issue is the charging system of the truck; allow the battery to charge or repair the charging system on the truck.

REFERENCE #5

Excessive Voltage Drop:

Step 1: Check wires and connections from dual/single pole nose box to Select Controller, making sure wires are undamaged and connections are clean and tight.

Step 2: Disconnect the stinger cord, apply a load of about 25 amps, and measure the voltage. Voltage must remain above 10.5 volts. If not, test the stinger cord and the wiring in the truck (wires from truck battery to dual/single pole connection on truck).



SERVICE TIP - Purkeys offers the Liftgate Double Check tool, which can simplify the diagnosis of liftgate charging system problems caused by excessive voltage drop. For more information on the tool, please call 1-800-219-1269 or visit our website at www.purkeys.net.

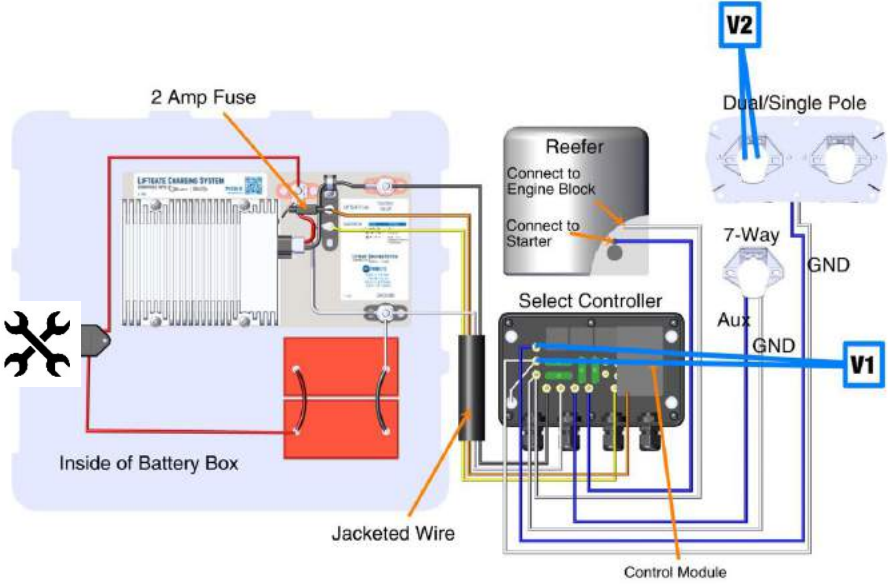

Figure 9

REEFER DIAGNOSTICS

Start the reefer unit and unplug the stinger and 7-way cord (see Figure 10 for location of Reefer LED; see Figure 11 for LED status reference, located on right side of Select Controller).



Figure 10



Figure 11

SELECT DIAGNOSTIC GUIDE

LED STATUS	CONDITION	ACTION NEEDED	REFERENCE
Solid Green	Charging with reefer as source.	Verify that liftgate battery is charging (see Charging Diagnostics section on page 19).	
Slow Flashing Orange	Input voltage from the reefer cord has dropped to less than 12.4 volts.	Determine cause for low voltage condition and repair.	Ref #7
Slow Flashing Green	Input voltage from reefer is between 12.4 and 13.8 volts.	Determine cause for low voltage condition and repair.	Ref #7
Rapid Flashing Orange	Blown fuse on the reefer circuit.	Repair the circuit and replace the fuse.	Ref #6
No LED	No voltage from the reefer connection.	Determine where the problem exists and repair or replace the circuit.	Ref #7
Green, then Toggling Orange and Repeating	Excessive voltage drop.	Replace or repair the source power and ground wire harness.	Ref #8

REFERENCE #6

Rapid Flashing Orange LED: Blown fuse on the reefer circuit. Replace the fuse (see Figure 12 for reefer fuse location).

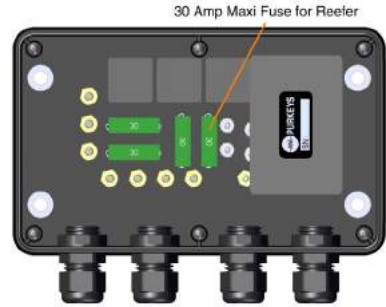

Figure 12

REFERENCE #7

Input voltage has not reached 13.8 volt turn-on threshold. Follow the steps below to diagnose.

Step 1: With the reefer running and the stinger and 7-way cord unplugged, use a voltmeter to measure the voltage between the reefer ground stud and the reefer positive stud inside the Select Controller (see V1 in Figure 13). It should read 13.8 volts or greater. If yes, and the light still is not solid green, call customer service as the Select Controller or Control Module may be defective. If no, proceed to step 2.

Step 2: With the reefer running and the stinger and 7-way cord unplugged, use a voltmeter to measure the voltage between the reefer engine block ground stud and the reefer starter positive stud (see V2 in Figure 13). It should read 13.8 volts or greater. If yes, repair or replace the wiring between the reefer unit and the Select Controller. If no, check the reefer alternator and the wiring between the reefer alternator and the reefer starter. Repair or replace.

REFERENCE #8

Excessive Voltage Drop: Check wires and connections from reefer to Select Controller, making sure wires are undamaged and connections are clean and tight. Wires, connections, and reefer charging system must be able to supply at least 10.5 volts with a load of 20 amps.

SELECT DIAGNOSTIC GUIDE

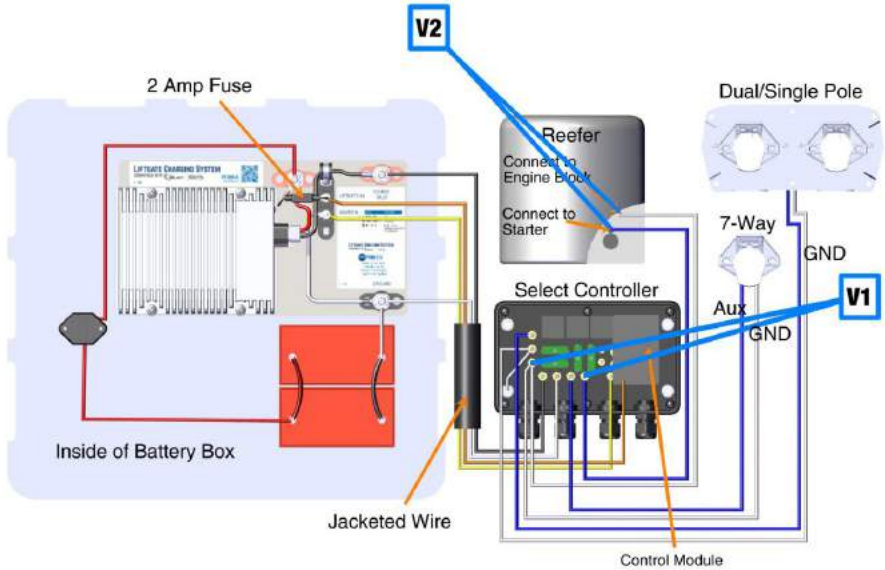

Figure 13

AUX DIAGNOSTICS

Start the tractor and unplug the stinger cord. Turn the reeper unit off (see Figure 14 for location of Aux LED; see Figure 15 for LED status reference, located on right side of Select Controller).



Figure 14



Figure 15

LED STATUS	CONDITION	ACTION NEEDED	REFERENCE
Solid Green	Charging with AUX as source.	Verify that liftgate battery is charging (see Charging Diagnostics section on page 19).	
Slow Flashing Orange	Input voltage from the AUX of the 7-way has dropped to less than 12.4 volts.	Determine cause for low voltage condition and repair.	Ref #10
Slow Flashing Green	Input voltage from AUX of 7-way is between 12.4 and 13.8 volts.	Determine cause for low voltage condition and repair.	Ref #10
Rapid Flashing Orange	Blown fuse on the AUX circuit.	Repair the circuit and replace the fuse.	Ref #9
No LED	No voltage from the AUX of the 7-way connection.	Determine where the problem exists and repair or replace the circuit.	Ref #10
Green, then Toggling Orange and Repeating	Excessive voltage drop.	Replace or repair the source power and ground wire harness.	Ref #11

REFERENCE #9

Rapid Flashing Orange LED: Blown fuse on the AUX of 7-way circuit. Replace the fuse (see Figure 16 for AUX fuse location).

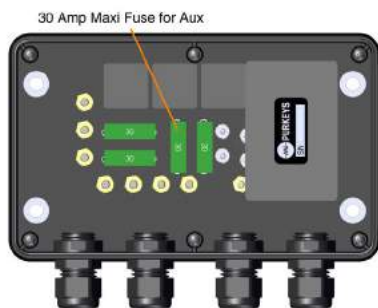

Figure 16

SELECT DIAGNOSTIC GUIDE

REFERENCE #10

Input voltage has not reached 13.8 volt turn-on threshold. Follow the steps below to diagnose.

Step 1: With the reefer unit off and the stinger unplugged, plug in the 7-way cord. Start the tractor and let the engine run. Use a voltmeter to measure the voltage between the AUX ground stud and the AUX positive stud inside the Select Controller (see V1 in Figure 18). It should read 13.8 volts or greater. If yes, and the light still is not solid green, call customer service, as the Select Controller or Control Module may be defective. If no, proceed to step 2.

Step 2: With the reefer unit off and the stinger cord unplugged, plug in the 7-way cord. Start the tractor and let the engine run. Use a voltmeter to measure the voltage between the AUX center pin and the top ground pin on the 7-way receptacle on the trailer (see V2 in Figure 18). It should read 13.8 volts or greater. If yes, repair or replace the wiring between the 7-way receptacle on the trailer and the Select Controller (check the wiring, connections, and fuses, if existing, in the 7-way nose box). If no, measure the voltage at the truck battery. If the reading is greater than 13.8 volts, the issue is in the wiring from the 7-way to the truck. If the reading is less than 13.8 volts, the issue is the charging system of the truck; allow the battery to charge or repair the charging system on the truck.

REFERENCE #11

Excessive Voltage Drop:

Step 1: Check wires and connections from 7-way nose box to Select Controller, making sure wires are undamaged and connections are clean and tight.

Step 2: Disconnect the 7-way cord, apply a load of about 25 amps between the AUX and ground pins, and measure the voltage. Voltage must remain above 10.5 volts. If not, test the 7-way cord and the wiring in the truck (wires from truck battery to 7-way connection on truck).

7-way Nosebox Tips:

- Inspect circuits inside the 7-way box for excessive electrical resistance caused by overheating, corrosion, loose/poor connections, or undersized wiring.
- Check to see if the 7-way nosebox is equipped with circuit breakers (see Figure 17), as the problem may be a failing circuit breaker. Either replace circuit breaker with a new part or connect the blue wire from the Select Controller to the unprotected side of the circuit breaker. Circuit protection is provided by the 30 amp fuse inside the Select Controller.
- Ensure the 7-way or stinger cord has a tight fit and has good electrical contact at the tractor and trailer receptacles.



Figure 17: 7-Way Nose Box



SERVICE TIP - Purkeys offers the Liftgate Double Check tool, which can simplify the diagnosis of liftgate charging system problems caused by excessive voltage drop. For more information on the tool, please call 1-800-219-1269 or visit our website at www.purkeys.net.

SELECT DIAGNOSTIC GUIDE

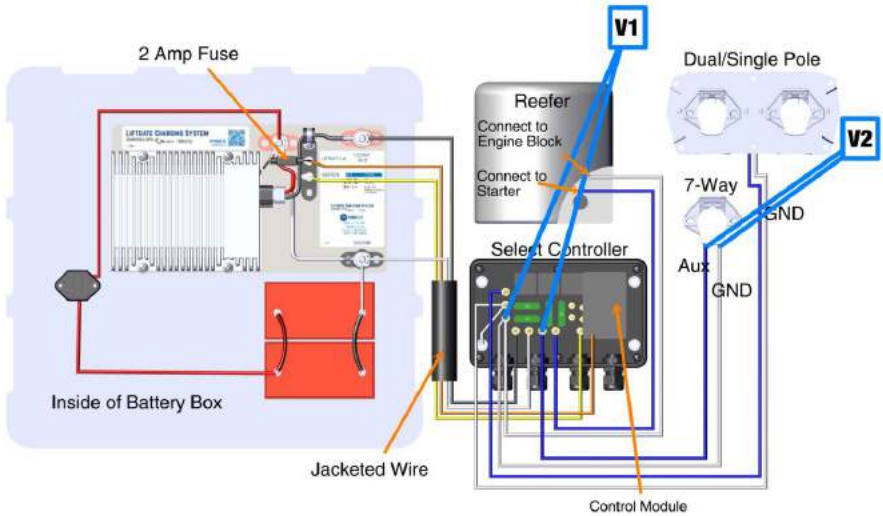

Figure 18

CHARGING DIAGNOSTICS

Charging from one of the available sources (one of the source LEDs is Solid Green). The Lift Battery LED status is as listed in table below (see Figure 19 for location of Liftgate Battery LED; see Figure 20 for LED status reference, located on right side of Select Controller).



Figure 19



Figure 20

LED STATUS	CONDITION	ACTION NEEDED	REFERENCE
Solid Green	Charging.	None.	
Slow Flashing Green	No charge or liftgate battery voltage has not yet exceeded 13.2 volts.	Allow time for the liftgate battery to charge. Check the DC/DC converter and circuit protection.	Testing the DC/DC converter
Slow Flashing Orange	No charge or liftgate battery voltage has not yet exceeded 12.8 volts.	Allow time for the liftgate battery to charge. Check the DC/DC converter and circuit protection.	Testing the DC/DC converter
Rapid Flashing Orange	Open ground fuse.	Repair circuit and/or replace fuse.	Ref #1
No LED	Open circuit from liftgate battery positive and Select Controller or disconnected ground in liftgate battery box.	Repair circuit, reset circuit breaker, or replace fuse.	Ref #2

SELECT DIAGNOSTIC GUIDE

TESTING THE DC/DC CONVERTER

See Figure 21 to see the LED lights on the DC/DC converter. A rapid flashing red LED on the converter is normal if the trailer is disconnected from a running truck. It will continue to flash for a short period of time. A rapid flashing red LED is only a fault if the trailer is connected to a running truck.

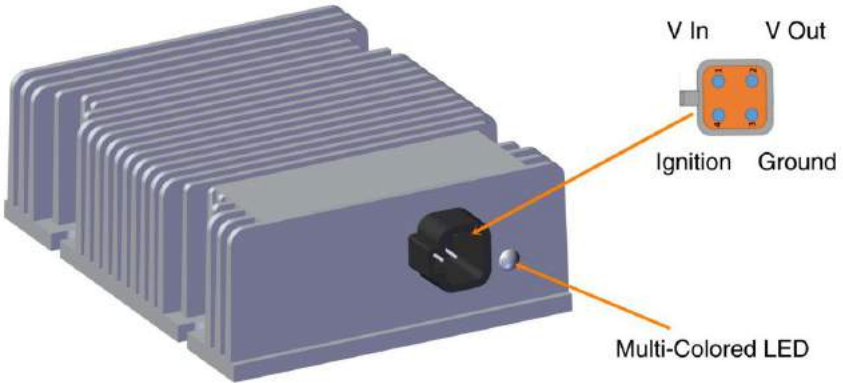

Figure 21

LED STATUS	CONDITION	ACTION NEEDED	REFERENCE
Solid Green	DC/DC converter is on.	Ensure circuit protection on output side is in working order.	Ref #13
Rapid Flashing Red	DC/DC converter has a fault.	Determine the fault.	Ref #12 & #13
No Light	No voltage.	Determine the fault.	Ref #12 & #13

REFERENCE #12

Steps to test power to the DC/DC converter:

Step 1: Look at the Source LEDs on the Select Controller and ensure that one of them is Solid Green. If no, refer to the Stinger, Reefer, or Aux Diagnostics sections. If yes, measure the voltage at the DC/DC Converter Input (+) stud and Ground (-) Liftgate Battery (Fused) stud (see V1 on Figure 22). Voltage should be over 10.0 volts. If yes, go to step 2. If no, check 30 amp maxi fuses for the ground, stinger, reefer, and aux. If fuses are good, and voltage is still below 10.0 volts, replace the Control Module. If, after replacing the Control Module, the system still does not function properly, replace the Select Controller.

Step 2: With a voltmeter, measure the voltage at the ignition output (see V2 on Figure 22). Should be over 10.0 volts. If yes, skip to step 3. If no, replace Control Module.

Step 3: With a voltmeter, measure the input and ignition voltages at the P1020-K Liftgate Charging System Plate Assembly (see V3 and V4 on Figure 22). Both should be over 10.0 volts. If no, repair or replace the wires between the Select Controller and the P1020-K Liftgate Charging System Plate Assembly. If both voltages are over 10.0 volts, move to reference 13.

REFERENCE #13

Steps to testing the DC/DC converter:

Step 1: After completing the steps in Reference #12, check the circuit breaker. Reset the circuit breaker if tripped.

Step 2: Check to verify that the DC/DC converter is charging the batteries. This can be done by measuring the voltage at the battery or by measuring the current going to the battery. If the voltage is above 14.0 volts, OR if the voltage is rising over time,

SELECT DIAGNOSTIC GUIDE

OR if current is flowing into the battery, the DC/DC converter is charging the batteries. See A, B, or C below for details on how to make these measurements.

- A. Measure the voltage at the liftgate batteries (see V5 on Figure 22). If higher than 14.0 volts, the charging system is functioning properly.
- B. If the voltage at the liftgate batteries is below 14.0 volts, use a voltmeter to monitor the voltage at the liftgate batteries for 2–5 minutes (see V5 on Figure 22). If the voltage rises, the DC/DC converter is functioning properly; allow time for the batteries to charge.
- C. Using a clip-on ammeter, measure current flow (see clip-on ammeter on Figure 22). If above 10.0 amps, the system is working. Allow time for the liftgate batteries to charge.

NOTE: If the voltage at the liftgate batteries is above 14.0 volts, and the batteries are fully charged, the current will taper down to under 10.0 amps.

If the DC/DC converter is not charging, check the wiring and connections to the DC/DC converter. If problem continues, replace the DC/DC converter.

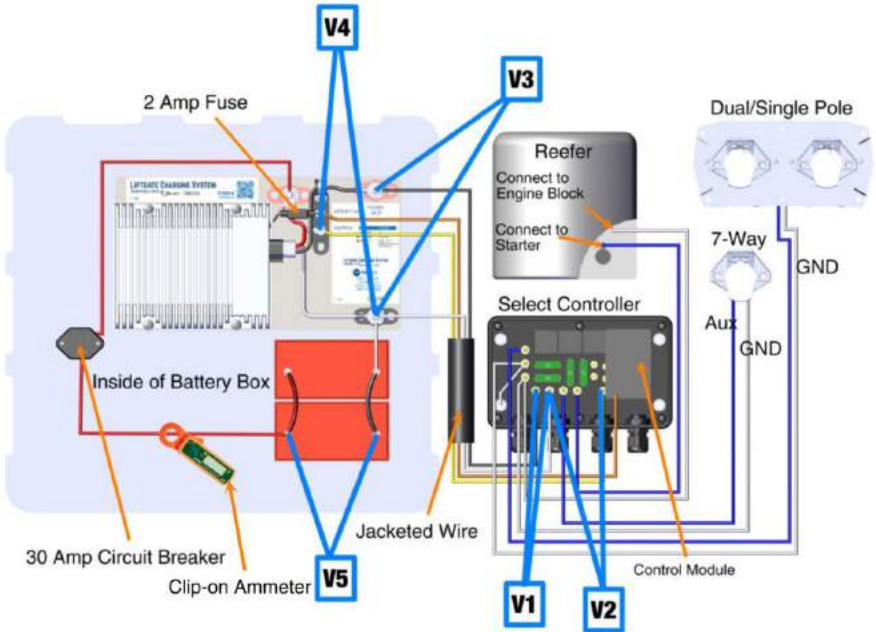







Figure 22





SELECT DIAGNOSTIC GUIDE



SUMMARY

LED Status		Logic
 <p>Solid Green on Lift Battery and Source</p>	<p>Charging State – Source voltage is greater than 13.8 volts. DC/DC converter is on. Tractor or Reefer must be running and alternator good to achieve 13.8 volts. A batteries surface charge cannot reach this value.</p> <p>Applies to all charging sources</p> <p>Note: The turn on voltage is 13.2 volts after 5 mins or 13.8 volts immediately. Reason is that if in Dual Pole in Parallel state, the Select input is now connected to liftgate batteries via the dual pole cables. If the liftgate batteries had been charging using the DC/DC converter, then that voltage would be above 13.2 volts so therefore the Select would turn on and continue to charge even if the tractor or Reefer was shut off.</p>	
 <p>Solid Green on Source Slow Flashing Orange on Lift Battery</p>	<p>Charging State- Tractor or Reefer connected and running. DC/DC converter is operating but the liftgate batteries are defective or below 12.8 volts.</p> <p>Applies to all charging sources</p>	

LED Status		Logic
	<p>Solid Green on Lift Battery and Source</p>	<p>Extend State – Source voltage drops below 13.8 volts. DC/DC converter is on for 1 hour. Every two minutes the controller turns off the DC/DC converter so there is no current flow (no voltage drop) and measures the battery voltage on the tractor batteries. If over 12.4 volts, the controller turns on for another two minutes. This will repeat until 60 minutes has expired or the voltage drops below 12.4 volts for 30 seconds. The Select will then look for next available source.</p> <p>Note: Reefer extend period is .5 hours</p>
	<p>Dual Pole or Reefer in Parallel Mode</p> <p>Solid Green on Lift Battery and Source</p>	<p>Extend State – If tractor dual pole is uncoupled, reefer turns off or voltage drops below 12.6 volts (dual pole coupled, but engine off). Then it will extend for approx. 2 minutes and turn off. If voltage at dual pole does not drop below 12.6 volts, then extend time will be longer.</p>
	<p>No Source LED</p> <p>Lift Battery LED Slow Flashing Green</p>	<p>Static State – No tractor connected to the trailer and the liftgate batteries are more than 12.4 volts.</p>

SELECT DIAGNOSTIC GUIDE

LED Status		Logic
	<p>No Source LED Lift Battery LED Slow Flashing Orange</p>	<p>Static State – No tractor connected to the trailer and the liftgate batteries are less than 12.4 volts.</p>
	<p>Slow Flashing Green on Lift Battery and Source</p>	<p>Off State – Source voltage below 13.8 volts and extend period is over. Voltage at the lift batteries and the source is above 12.4 volts. Voltage at source must achieve 13.8 volts to go into Charging State.</p> <p>Applies to all charging sources</p>
	<p>Slow Flashing Orange on Lift Battery and Source</p>	<p>Off State (Low Voltage) – Lift battery and source voltage below 12.4 volts. DC/DC converter is off. Voltage at source must achieve 13.8 volts to go into Charging State.</p> <p>Applies to all charging sources</p>
	<p>Rapid Flashing Orange on Lift Battery and/or Source</p>	<p>Off State (Fault) – Blown ground fuse if flashing on lift battery and blown source fuse if flashing on source.</p>
	<p>No LED</p>	<p>Off State (Fault) – Open circuit in lift battery or source circuit. This could also be caused by the liftgate battery voltage being below 6 volts.</p>

LED Status		Logic
		<p>Excessive Voltage Drop – Tractor or Reefer is running and the voltage is above 13.8 volts. The controller turns on the DC/DC converter and current starts to flow. If the voltage drops below 10.5 volts, the controller will tell the DC/DC converter to turn off. What the operator will see is the Source and Lift Battery go Solid Green. Then both LEDs will toggle orange for a few seconds. The cycle then repeats.</p> <p>Note: Low voltage shut off in the 1st 5 mins is 9.5 volts.</p>

SELECT DIAGNOSTIC GUIDE

LIMITED COMMERCIAL WARRANTY POLICY

Purkeys Fleet Electric, Inc. (hereafter "Purkeys"), warrants each product to be free of defects in material or workmanship under normal use and service. This warranty is for the benefit of Original Equipment Manufacturers, Dealers, Warehouse Distributors, Fleets, or other End Users (hereafter "Customers") and covers products manufactured by Purkeys and sold new to Customers either directly by Purkeys or by its authorized dealers, distributors, or agents. The length of the Warranty Period is 36 months.

The warranty period commences on the in-service or install date and is not transferable. Failure to provide the in-service or install date on the warranty claim form will cause the warranty period to begin on the date the part was manufactured or date of sale recorded on the original sales invoice, whichever is earlier.

A completed warranty claim form should accompany all parts submitted to Purkeys for consideration for repair or replacement under warranty. The submitted claim form should contain all of the information required. Lack of a properly or fully completed claim form will result in delay or denial of warranty claim. Claims must be submitted no later than 30 days after part is removed.

This warranty does not apply if, in sole judgement of Purkeys, the product has been damaged or subjected to accident, faulty repair, improper adjustment, improper installation or wiring, neglect, misuse, or alteration or if the product failure is caused by defects in peripheral vehicle components or components attached to the Product or failure of a part not manufactured by Purkeys.

This warranty shall not apply if any Purkeys product is used for a purpose for which it is not designed or is in any way altered without the specific prior written consent of Purkeys. ANY Product alleged by a Customer to be defective must be inspected by Purkeys as a part of the warranty claims process in order to confirm that the part has failed as a result of a defect in material or workmanship.

Transportation for products and parts submitted to Purkeys for warranty consideration must be prepaid by Customer. Repaired or replaced products and or components will be returned to Customer pre-paid by Customer or "freight collect" to the address provided by Customer in the warranty claim form. No charge will be made for labor or material in effecting such repairs.

The Warranty provided by Purkeys hereunder is specifically limited to repair or replacement of the Product as Purkeys deems most appropriate in its sole discretion. Purkeys neither assumes nor authorizes any other person to assume on its behalf any other warranty or liabilities in connection with Purkeys products. The Warranty does not apply to fuses or other "consumable" or maintenance items which are or may be a part of any Purkeys product.

THIS WARRANTY DOES NOT APPLY TO LOSS OF VEHICLE OR EQUIPMENT, LOSS OF TIME, INCONVENIENCE, OR OTHER INCIDENTAL OR CONSEQUENTIAL DAMAGES. PURKEYS SPECIFICALLY DISCLAIMS AND SHALL NOT BE LIABLE FOR INCIDENTAL OR CONSEQUENTIAL DAMAGES arising out of or from the use of Purkeys products by the Customer.

THIS LIMITED WARRANTY IS IN LIEU OF ALL OTHER WARRANTIES, INCLUDING COMMON LAW WARRANTIES OF FITNESS FOR A PARTICULAR PURPOSE, MERCHANTABILITY, AND ANY OTHER EXPRESS OR IMPLIED WARRANTIES. ALL OTHER SUCH WARRANTIES ARE SPECIFICALLY DISCLAIMED.

This Limited Commercial Warranty supersedes all previous Warranty Policies issued by Purkeys and any of its suppliers.



WATT Keeps You Trucking